

RCY-C Series separator

1. Summary

Attractive force can only happen on ferrous materials in the non-equal magnetic field. The attractive force (F) is proportional directly to the product of the magnetic intensity (H) and the magnetic gradient ($\frac{\partial H}{\partial L}$). We consider both the two parameters above-mentioned are important in our designing this kind of equipment.

The magnetic curves can be concentrated under the equipment because of the unique magnetic circuit specially designed. This kind of equipment has not only high magnetic gradient, but also high magnetic intensity at the suspension height rated under the equipment. Even at the same magnetic intensity, the magnetic gradient of this kind of equipment is superior. Ferrous iron in different shapes, from 0.1kg to 35kg in weight can be caught

2. Structure

Magnetic separators are divided into two kinds according to different discharging method: Automatic discharge and humanly discharge.

Automatic discharge magnetic separator (1) (RCY-C): made of magnetic system and frame, discharging belt, driven drum, pulley, motor, motor and speed reducer compose a whole, and to drive the chain, wheel, driven belt and scraper to discharge iron automatically. (2) (RCY-P II): The speed reducer is placed on the middle of bridging beam. This structure saves the space, which is suitable for strict working space and

RCY-C Series separator

with the same working capacity with C type.

Manual magnetic separator (RCY-P): an axis chain wheel and two half of axes are stocked on two ends of magnetic system, and the chain round across of the chain wheel on the two ends of axis come into a close cycle. The scraper and the chain on both sides, the scraper clings on the magnetic system and moves forward on the surface. Discharge the iron scrape by remover handle. The separator is suspended upon the head of belt conveyor to remove the iron.

3. Outline of magnet (Attn Chart 1) & Main technical (Attn Chart 1)

4. Suspending device

4. 1 Adapted suspending device for main body of magnetic separator (Attn: Chart 2) and walking device (Chart 4)。

4. 2 Suspension Device :

Notice: the inclination between two suspending devices is less than 60°

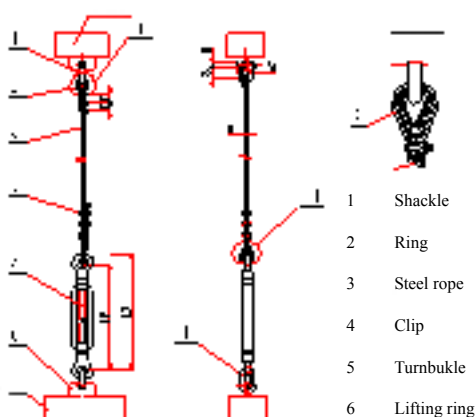

1. Length of each suspending device is L, decided by consumer.
2. Notice on steel rope & suspending device
 - (1) Rope clip must assemble in the same direction.
 - (2) U shape bolt of rope clip must buckle on the end, and rig mount fixed on other side of working segment
 - (3) Length of steel rope determined by operating spot.
 - (4) Contact every ends of suspending device with shackle.
 - (5) Quantity and distance of rope clip as bellows chart:

The dimension of rope clips (diameter of steel cable)	Quantity of rope clips of each group	The distance between Rope Clips (C)
≤ 19	3	(6-7). d
> 19-32	4	

RCY-C Series separator

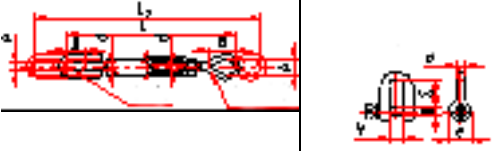
Para.		Weight (kg)	Steel Rope (GB1102-74) Qty:4	Steel Clip (GB5976-86)	Ring (GB5974.1-86) Qty: 8		
No.	Mod						
1	RCY-C50	680	Dia. of rope d=9 Length L=2000	Spec.: 10KTH	Spec.: 10KTH	Hulu Tianli Rigging d=3/4 in A=25.4 B=53 L=568.5 L1=911.4 Load: 2359kgs	JB8112-1995
2	RCY-C65	830					M16
3	RCY-C80	1100					DMAX=16 Dmax=14 Wmin=16 Emax=35.2 Load: M(4)1000kg
4	RCY-C100	1710	Dia. of rope d=12 Length L=2500	Spec.: 12KTH	Spec.: 12KTH	Hulu Tianli Rigging 5/8in D=19.3 D=16 W=27 S=50.8 e= 38.1 Load: 3520kg	Hulu Tianli Rigging
5	RCY-C120	2292					
6	RCY-C140	3080	Dia. of rope d=16 Length L=2700	Spec.: 16KTH	Spec.: 16KTH	LXKA4 d=M27 A=32 B=86 L=782 L1=1102 Load: 4000 kg	Hulu Tianli Rigging
7	RCY-C150	4130					

RCY-C Series separator

4. 3 Electro (DX)and Manual (SDX) working device are as follows:

- (1) SDX-1.1Manual Single Tramroad & Single Trolley (2)SDX-1.Z Manual Single Tramroad Combination Trolley
DX- 1.1Electric Single Tramroad & Single Trolley DX-1.Z Electric Single Tramroad Combination Trolley

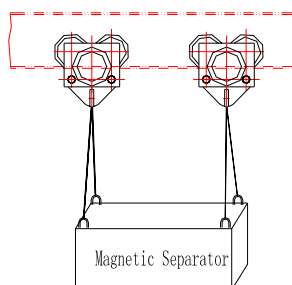
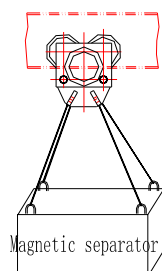

- (3)SDX-2.Z Manual Double Tramroad Combination Trolley
DX-2.Z Electric Double Tramroad Combination Trolley

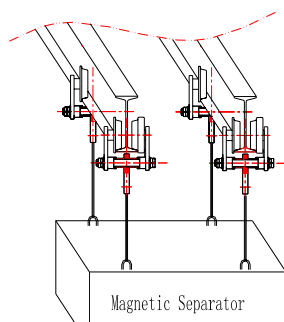

RCY-C Series separator

4.3.1 Adjust gasket to make the space between wheel and I tramroad to 3~4mm:

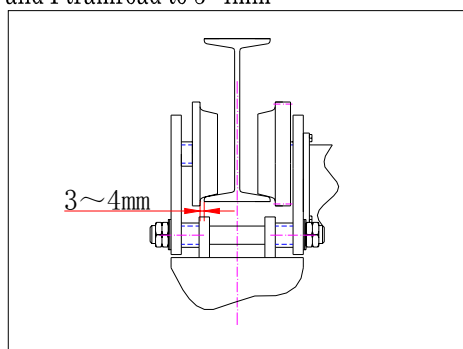

4. 4 Fixation suspension methods: Tramroad is free, and it be installed on the ceiling or I girder.

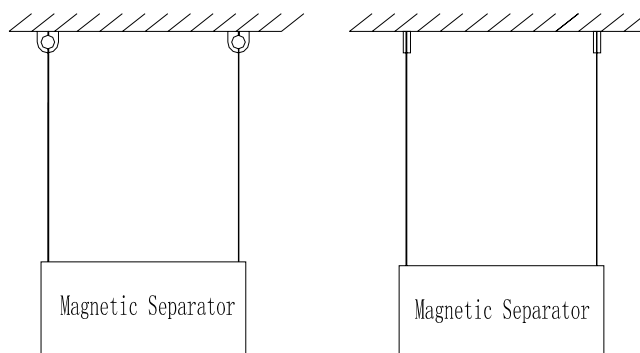

5.Preparation

5. 1Preparation for installation

5. 1. 1 Choose installing position

5. 1. 1. 1 Locates above the unload head of conveyor if equipment assembled aslant.

RCY-C Series separator

5. 1. 1. 2 Vertically above the appropriate position of conveyor if equipment assembled horizontally.

5. 1. 2 Assembling on I girder

5. 1. 2. 1 Choose the model of I girder according to the suspending device and working device.

5. 1. 2. 2 Only one or two single girders are need for one magnetic separator.

5. 1. 3 Check if the wire connection, every parts of magnetic separator and control panel are all in good condition on the ground firstly, and to check if the belt run off track. If any unconventionality happens, adjust it according to the operating manual.

5. 2 Operation Mode:

5. 2. 1 Magnetic separator working over the head of conveyor

5.2.1.1 The sketch for belt magnetic separator suspend as follow:

5.2.1.2 The sketch for manual magnetic separator suspend as follow:

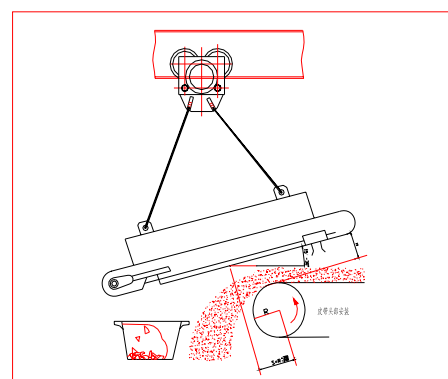
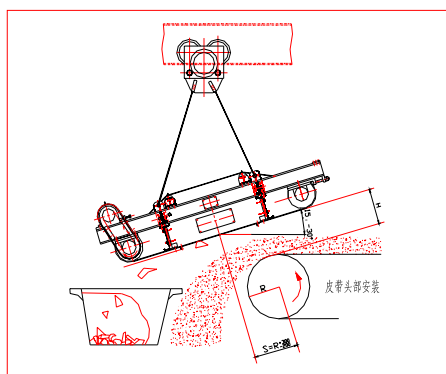

The magnetic be suspended over the head of belt conveyor, obliquity $\alpha = 15^\circ - 30^\circ$. If

RCY-C Series separator

belt-running speed is more than 2m/s, the magnetic separator can be installed a little away from the pulley. The projectile motion of material is good help to magnetic separator to catch tramp iron. When the speed lower than 2m/s, then the magnetic separator is better to near to the head pulley. Non-magnetic pulley is good for separation result.

●Suspending poison

How to decide the distance S that between central line of magnetic system and center of belt conveyor pulley:

Many factors such as R of drum , linear velocity of belt conveyor, viscosity of the material, and installing obliquity of magnetic separator, H determined that S,

generally $S = R - 200 + 300$.

5.2.2 Working over the middle of belt conveyor:

5.2.2.1The sketch for belt magnetic separator suspend as follow:

5.2.2.2The sketch for manual magnetic separator suspend as follow:

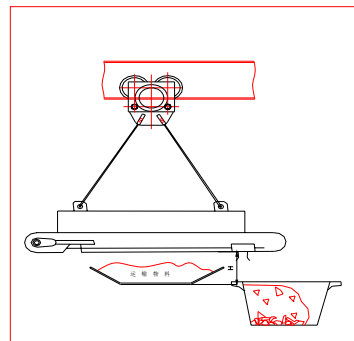
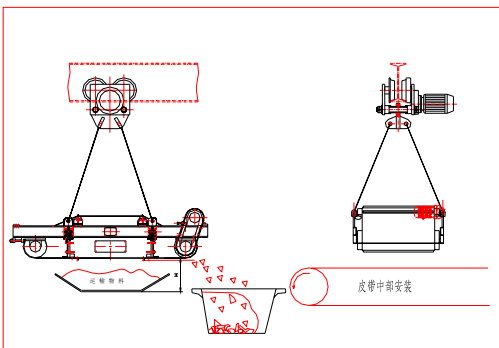

RCY-C Series separator

5.2.2.1

Magnetic separator can be used over the belt conveyor, packing label and vibrating screen etc. The running direction of the belt of magnetic separator is vertical to the running direction of belt conveyor. And remove the tramp iron automatically in the vertical direction of conveyor belt.

●Suspending poison

1)Center of magnetic core just face to the center of conveyor's belt.

2) The motor of magnetic separator should

be put in the lower position and the obliquity of magnetic separator should not exceed 15° as magnetic separator is installed over the middle of belt conveyor.(Attn. To above chart)

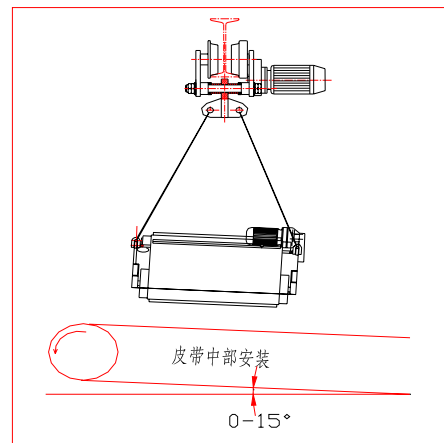

6. Check, adjust and preoperation after installation

6.1 As double tramroads are used for one magnetic separator, the distance deviation between tramroads should be within $\pm 2\text{mm}$.

6.2 Look over the reliability of waling device.

6.3 Look over the reliability of suspending device.

6.4 Check the parallelism and suspension height as the magnetic separator is installed

RCY-C Series separator

over the middle of belt conveyor.

6.5 Adjust the position to warranty the suspension height H , $\alpha = 15^{\circ} - 30^{\circ}$, $S = R_{-200}^{+300}$ as the magnetic separator is installed over the head pulley,

6.6 Preoperation Test: Test whether the separators work alternatively under the program settled stably and reliably. Make sure the catching and discharging points works on the rails.

Load-free running should cover more 10 times.

6.7 Man-made some trouble to inspect the acousto-optic alarm system.

7. Working preoperation

7.1 Mainly include items: if the direction of the remove iron belt is right, if the separator's catch and remove iron is right after limited, if the assemblage is suitable, the working status of running device.

7.2 In order to test the ability to catch and remove the iron and the efficiency to remove the iron, customer may throw iron pieces in different weight to the separator. (Don't throw sharp and over-weight iron tramp onto the belt.

7.3 Separators though 2weeks running without any trouble can be used for normal production.

8. Lubrication

RCY-C Series separator

Parts Lubricated		Grease		Lubrication Period			
Bearings on both ends of the primary and the secondary drums		Calcium Grease or Natrium Grease		5-6 months			
Speed reducer		(Ditto)		(Ditto)			
part	mode 1	Type of lubricate oil/grease		In point temperature	In point area		
Planet cycloid pin wheel reducer	4	Lubricate grease	No.00 speed reducer grease			Common area	
			Calcium Grease or Natrium Grease		-1 to (60)110		
			General lithium grease		-20 to 120		Low temperature or common area
			Anhydrous calcium grease		-45 to 100		Cold area
	5	Industry extremity press gear oil	Homemad e	40 (30)	-10 to 5	Low temperature area	
			ISO	EP68			
			Homemad e	70	0 to 35	Common area	
			ISO	EP150			
			Homemad e	90	30 to 50	High temperature area	
			ISO	EP220-460			
	Common industry gear oil		9 kinds of oil such as (SY1172-80)50 etc.		-8 to 170	Common area	

RCY-C Series separator

		Low coagula te industr y gear oil	68、100、150、220、320、 460 produce by No.1 petro-plant of Fushun, China.	-50 to 100	Cold area
Lubrication period	<p>1.Changing the oil after running 2 weeks if it is a new machine, and the smeariness should be washed down.</p> <p>2.4-6 months on working order.</p> <p>3.Shorten the lubrication Cyc if the temperature condition is higher than usual or the humidity is bigger than usual.</p>				

9. Ordinary fault analysis

Phenomena	Causation	Eliminate Method	Memo
Catch, remove iron ability becomes weaker	Suspending height or obliquity changed	Adjust the Suspending height or obliquity	
Belt off track	Driving pulley and driven pulley and the parallel of pulley support are changed	Attention to the deviation adjustment method	Only for belt magnetic separator
Lubrication and noise increase	Joint parts become flexible	Fasten joint parts	
Walking device	Contracting brake of walking device is too tight	Dismantle the paddle cover at the back end, adjust 3 fasten bolt. To the working device still move 50~150mm after power off.	Only for electric-walking device

RCY-C Series separator

How to adjust the belt off track:

Firstly, adjust the pulley support, if the adjustment reach to it's limit, the belt still runs off track, then adjust the driven pulley bearing seat according to chart. If the belt still runs off track, then adjust the bearing seat of driven pulley.

(1) Watch down to the direction shows in above chart, if the belt deviate to left as above chart, adjust the any one of pulley support 1.2.3.4, as the method shows in chart a , if the pulley support reach its adjusting limit, then adjust other pulley support till the belt stop deviating. Adjust the bearing seat on driven pulley as of all as the four pulleys support are all reach to their limit. Adjust the one of 1, 2 bearing seats on

RCY-C Series separator

driven pulley to suitable position along the direction shows in above chart, as the bearing can't adjust anymore, then adjust the other bearing seat to the belt runs in right track.

(2) Watch down to with the direction shows in above chart, if the belt off track to right as chat b, the adjusting method is just as the contrary to chart a.

Caution on belt adjustment:

(1) Don't trample the belt during the belt adjusting process, otherwise will influence the adjustment on belt.

(2) If the belt off track to a side, then exchange any phase of the input line on 3phase motor, then the belt will run to the contrary direction., and move to the other side, when the belt move to the middle of magnetic separator, stop it, and recover the connection of input line, and belt running direction. Afterward, adjust the deviation according to above method.

(3) After the belt not deviate any more, then runs the magnetic separator for 2 hours, watch the running status. If the deviate, adjust it in time.

10. Easy Worn-out Part (Attn to Chart 3)

11. Caution

RCY-C Series separator

11.1 Don't disassemble the magnetic core for no damaging the magnetic performance of the separator.

11.2 Baste appointed Lubrication according to item 8, oil and grease can't mix up.

11. 3 It's danger to take ironware nearby the magnetic system.

11.4 Don't bring any ferrous or easily magnetized matters e.g. watch, magnetic card and so on nearby the separator.

11.5 Starting with load is strictly prohibited! The customer should start the separator first, then the belt conveyer.

11.6 If the condition is permitted, try to make the suspension height lower to improve the separating efficiency.

11.7 Use canopy while the equipment working outside.

11. 8 Calcium grease should be basted on suspending device after work, if the magnetic separator is used at seaside.

12.Maintenance

12.1 Check if the cable is worn out or the connecting terminals are bad connect frequently. (Only for belt magnetic separator)

12. 2 Every connectors should be maintained periodically to assure their stability and safety.

12.3 Lubricate the driving parts periodically (Attn. to part 8 Lubrication)

13. Transport and Store

13.1 The separator should be close packaged, ventilated and waterproof when

RCY-C Series separator

transport.

13.2 The separator should be deposited in a ventilated and dry storehouse.

14. Opening and Checking

(1) If the equipment is in good condition? If the cable line and the junction-box are damaged.

(2) If the attached documents are complete?

The documents include:

a) Bill of Box up

b) Bill of Criterion

c) Appurtenance's Criterion and Description

d) Description of the Equipment

e) The Data About Ours Technical Service and Information Feedback.

RCY-C Series separator

15 Attachments

RCY-C SERIES OUTLINE SKETCH (Chart 1)

RCY-C Series separator

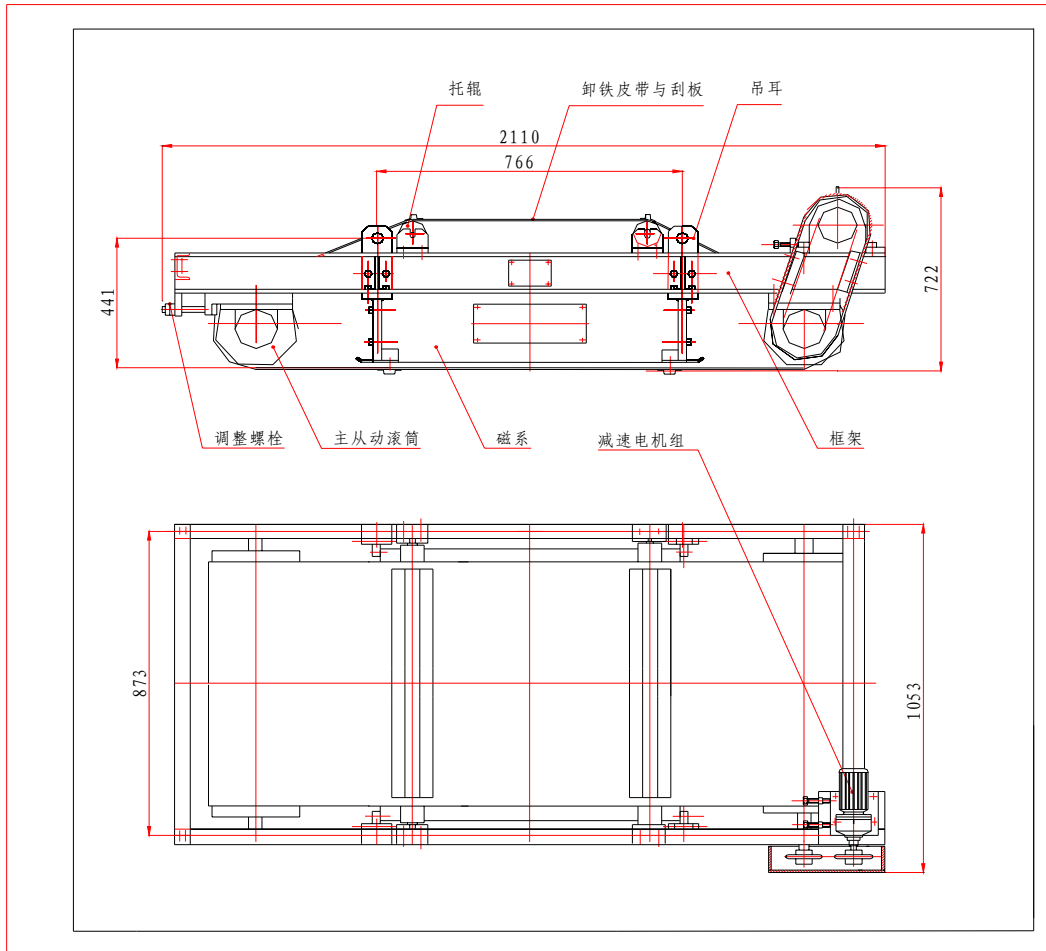

RCY-C Series separator

List 1 Main technical

Item Para. Model	Adaptive Belt Width (mm)	Rated Suspending Height H(mm)	Motor Power (kw)	Main dimension						Weight (kg)
				A	B	C	D	E	F	
RCY-C50	500	150	1.5	1970	903	722	620	647	451	700
RCY-C65	650	200		2110	1053	722	770	797		1000
RCY-C80	800	250	2.2	232	1253	722	970	997		1300
RCY-C100	1000	300	3.0	2690	1453	803	1120	1190		1700
RCY-C120	1200	350	4.0	2890	1713	868	1320	1430	516	2300
RCY-C140	1400	400		3090	1913	868	1520	1630		516
RCY-C160	1600	450	5.5	3310	2143	955	1760	1852	590	4150

List 2 Suspending Device

Item Para. Model	Steel shackle	Steel Rope			Turnbuckle		
		GB/T8918- 96		Steel Rope Clip	Model	Adjustable Distance	
		Dia. d	GB5974-86	GB5976- 86		Min.L	MaxL1
RCY-C50~80	M16	9	10	10	3/4in×12	568.5	911.4
RCY-C80-100	5/8in	9	10	10	3/4in×12	568.5	911.4
RCY-C120	5/8in	9	12	12	LXKB3	762	1062
RCY-C140~160	7/8in	16	16	16	LXKB3	762	1062

RCY-C Series separator

List 3 Easy Worn out Parts

Name Model Spec	Bearing on Driving, Driven Drum (GB/T288-94)	Bearing on pulley	Wheel	Chain (GB1243.1-83)
RCY-C50~80	22210C/W33	6305	Z=18	16A-1 P=25.4
RCY-C100~1 60	22212C/W33	6305	P=25.4	

List 4. Walking Device

Model	Manual double rail walking device			Manual single rail combination & single rail single trolley		
	SDX-2*Z-2	SDX-2*Z-4	SDX-2*Z-6	SDX-1*Z-1 SDX-1*1-1	SDX-1*Z-3 SDX-1*1-3	SDX-1*Z-5 SDX-1*1-5
Allowable Load	2	4	6	1	3	3
Power Source	Human power	Human power	Human power	Human power	Human power	Human power
Speed	Control by operator	Control by operator	Control by operator	Control by operator	Control by operator	Control by operator
Model of I rail GB706-88	16a~28b	20a~32c	25a~63c	16a~28b	30a~32c	25a~63c